

Novel Approaches to Miniature Flight Platforms

Robert C. Michelson
Georgia Tech Research Institute
GTRI-ATAS-CCRF
7220 Richardson Road
Smyrna, Georgia 30080 U.S.A.

ABSTRACT

No other air vehicle design space has presented the mix of challenges as that of miniature flight platforms. By definition these tiny platforms are unmanned and endeavor to invade the flight regime of birds and insects. In order to do so, the creators of these aerial robots must address the same physical design constraints which have already been mastered by the world of airborne biology, including low Reynolds number aerodynamics, high energy density, and extreme miniaturization. This paper focuses on the high degree of innovation required to make practical miniaturized flying machines on the scale of small birds and insects.

Keywords: aerial robot, micro air vehicle, biomimetic, biologically-inspired, Entomopter

INTRODUCTION

Flight fascinates mankind and from the beginning birds and insects have been the models by which flight was studied. The early designers of notional aircraft adopted inspiration from predominantly birds as reflected in the morphology of their creations. The problems of scaling biologically inspired designs up to human-carrying proportions were not appreciated and practically all failed principally due to the lack of an adequate propulsion system as exemplified by DaVinci's man-powered flapping wing machine.

More recently, attempts to move in the direction of tiny flying machines that match the scale of birds and even the smaller insects have come into vogue. The nature of flight at these scales is perhaps better understood by today's designers than it was by those of DaVinci's time, but beyond the first order appreciation for Reynolds number differences, the realm of miniature flight vehicles is still an unplumbed depth, with only a hand full of researchers working consistently in the area. Couple this with the difficulty of storing useful amounts energy in light weight packages at these small scales, and we end up with few practical designs and nothing that comes close to the endurance and performance of its biological counterpart.

Several fundamental problems exacerbate the development of very tiny flight vehicles. One of the first is the uncreative tendency toward biomimicry— basically, “if it works for the insects and I copy it, then it will work for me.” Another problem stems from a fixation on the air vehicle design to the exclusion of the propulsion system, leaving the designer with a compelling platform and no way to power it. Finally, were we able to accurately mimic the biological morphology of a common house fly, could we then manufacture it?

It would be easy to compare all of the attempts to create what is know as a Micro Air Vehicle or MAV, but that is not the intent of this technical paper; rather the design philosophies used to design this class of vehicles will be examined. The balance of the following discussion will address these fundamental issues of design and show that through creative innovation that extends beyond mere biological mimicry, one can achieve miniature flight platforms with useful performance envelopes.

A BRIEF HISTORY

“Micro Air Vehicle” is a most unfortunate name given to this class of air vehicles because none are truly “micro” and the original official Defense Advanced Research Projects Agency (DARPA) vehicle definition requiring a maximum 15 cm dimension confirmed the name to be a total misnomer.

Interest in tiny flying machines had its origins with the notion that a small insect-like flying platform could be devised for covert operations. It is rumored that the U.S. Central Intelligence Agency (CIA) dabbled briefly in this area in an attempt to create a remotely-controlled pneumatic “dragon fly”. A RAND Corporation study conducted in 1993 discussed the potential use of sensor-carrying insects and the concept of truly “micro” air vehicles [1]. Japanese researchers attempted to stimulate motoneurons in cockroaches to control the insect trajectory by a radio-link [2]. People also began testing tiny airplanes powered by biological motors (flies glued to a fuselage with fixed wings), a practice that was actually a subject of experimentation by Nikola Tesla [3].

During the early '90s, MIT Lincoln Labs conceived of a small airplane (see Figure 1) which could carry a tiny camera system that they had under development. Though it was quite doubtful that this notional platform model could ever fly, it did serve as a catalyst to begin serious discussion within the U.S. Government of the roles and missions for a micro air vehicle. During the mid '90s a picture of what was touted as the world's smallest helicopter appeared in the media (see Figure 2). Although this ultimately turned out *not* to be a free-flight vehicle (instead, a demonstration



Figure 1. MIT Lincoln Labs MAV concept model.

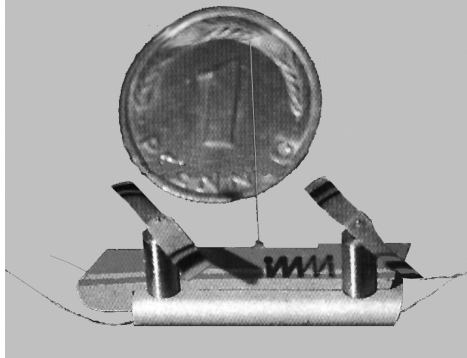

Figure 2. Device touted by some as the 'world's smallest helicopter'. [30]

of externally-powered subminiature electric motors turning small twisted paper propellers to cause a "fuselage" to rise up along a guide wire), it did rekindle interest in the notion of a "micro" air vehicle.

About the same time (ca. 1995) DARPA, under the lead of Col. Mike Francis, called a meeting of perceived stakeholders in the area of micro air vehicles to attend a workshop that would ultimately lead to the creation of a \$35M DARPA program (administered under Dr. Jim McMichael, DARPA Program Manager from 1996 to 1999) to develop MAV technologies and several MAV systems. Questions addressed by the stakeholders (which included among others, MIT Lincoln Labs, the Georgia Tech Research Institute, Sarcos Labs, and the U.S. Naval Research Laboratory) ranged from mission definitions, likely platform technologies, performance issues, and the definition of a "micro" air vehicle. Ultimately a micro air vehicle would be defined as "being less than 15 cm" because this represented the juncture at which low Reynolds number effects begin to dominate and beyond which, integration of energy, propulsion, aerodynamic structures, and intelligence is a necessity. This loose definition begged the question as to whether a MAV must fit within a 15 cm sphere, a 15 cm diameter cylinder, or a cube having 15 cm sides— the latter two interpretations allowing for diagonal dimensions greater than 15 cm. Also, could a MAV have moving parts (propellers or rotors) which when manually positioned were within the 15 cm limit, but once deployed could violate the defined volume? DARPA MAV program manager Sam Wilson (at DARPA from 1999 to 2003) indicated that all interpretations were equally valid [4], and it is apparent that those developing MAV prototypes have taken liberties to interpret the size definition to their advantage.

In 1997 DARPA selected six proposals to develop flight-enabling micro air vehicle technologies. These included,

- Massachusetts Institute of Technology's "Microelectromechanical Systems (MEMS) Based Micro-Gas Turbine Engines for Micro-Unmanned Aerial Vehicles (UAVs)"
- D-STAR Engineering's "Low-Observable, Safe-Operation, Fuel Efficient, Light Weight Propulsion and Power System for Advanced Micro Air Vehicles"
- Technology in Blacksburg Inc. "Thermoelectric-Based Advanced Micro-Air Vehicle (MAV)"
- SRI International's "Flapping-Wing Propulsion Using Electrostrictive Polymer Artificial Muscle Actuators"
- Vanderbilt University's "An Elasto-Dynamic Ornithoptic Flying Robotic Insect"
- California Institute of Technology's "Micro Bat" [5]

In addition, the Lockheed Sanders "Micro Star" electric fixed wing vehicle and the Lutronix Kolibri shrouded propeller electric VTOL vehicle, and eventually the Microcraft ducted fan were funded as systems demonstrations.

Four small businesses were also selected by DARPA to receive contracts under Phase II of the Small Business Innovation Research program. These included an IGR Inc. demonstration of a very lightweight Solid Oxide Fuel Cell, an M-DOT Inc. demonstration of a very small (1.4-pound thrust) gas turbine engine, an Aerodyne Corp. development of a hover vehicle that to explore the capabilities of the mini-scale engine being developed by M-DOT, and the Aero-Vironment Inc. flight demonstration of an electric-powered, fixed-wing, micro air vehicle called Black Widow [5].

These projects demonstrated varying degrees of performance ranging from poor to impressive, with the Aero-Vironment Black Widow being the most impressive; setting endurance, altitude, and range records. Little of this technology has transitioned into use today, and micro air vehicles are still an item for continued research. This can be attributed to not only the technical difficulty of the problem, but also some poor employment assumptions.

Back in 1997, DARPA's vision for MAVs was that the individual soldiers at the platoon, company or brigade level would use such vehicles for reconnaissance and surveillance, battle damage assessment, targeting, emplacing sensors, communications relays, or for sensing chemical, nuclear or biological substances. The 15 cm vehicles would be able to conduct real-time imaging, have ranges of up to 10 kilometers, and speeds of up to 30 miles per hour for missions that are 20 minutes to two hours long [5].

By 2004, this ambitious goal is still unattained and is not likely to be so for a number of years. The enabling technologies funded during the DARPA MAV program did not result in revolutionary advances nor has propulsion technology advanced sufficiently since then for the DARPA-envisioned performance levels to be achieved today.

Compounding the problem is the fact that the expectation for MAVs has been misfocused. The DARPA vision was for a predominantly outdoor asset. However, the same forces of nature that discourage insect and bird flight during thunder storms, are also at play when considering MAV flight. One might ask, is it tactically practical to expect soldiers to wait until the wind stops blowing before they can look for the enemy over the next hill? Warfighters must engage the enemy in all weather, not just calm sunny days.

Further, does size really matter in the "over-the-hill" scenario? Because not all technologies are scalable, limitations will be placed on MAV operations which impact navigation and communication. For example, a 15 cm MAV can only support a maximum antenna aperture of 15 cm (using the spherical size definition). Depending upon antenna type, this dictates a frequency of operation in the 2 GHz range. At this frequency, foliage penetration is difficult and line-of-sight transmissions are necessary. Were a soldier to send his MAV only 1 km ahead of his current position to look over a 30 m (98 ft) hill that is 60 m (196 ft) away, it would have to attain an altitude in excess of 500 m (1,640 ft) above the target area in order to avoid occlusion by the hill while maintaining line-of-sight with the soldier's ground control station. At this altitude the MAV would be neither seen nor heard... but neither would a larger air vehicle of perhaps ten times the size, as has been demonstrated on many occasions by existing "mini drones" such as the Aerovironment Pointer or NRL Dragon Eye. The difficulty in flying at the 15 cm scale is therefore unwarranted not only due to the difficulty in negotiating weather with marginal endurance, but also because fielded assets already exist to address this mission.

In spite of these issues, a strong case for MAVs does exist. The mission space for which size really does matter is "indoors and in confined spaces" where the environment is controlled or at least protected. No assets exist which can rapidly and covertly penetrate buildings, tunnels/caves, bunkers, and other enclosures. MAVs offer the potential to enter enclosures by non-obvious means (upper story openings), and navigate their interiors more effectively (e.g., circumventing obstacles such as stairs, and ground objects) and while doing it more rapidly than ground robots. They present a new paradigm in reconnaissance whereby close-in interaction is encouraged rather than a stand-off capability. Key to this behavior is small size, slow flight, and the ability to navigate without GPS.

CONFIGURATIONS

MAVs can be configured to operate in all the same ways that conventional aircraft do, including fixed, rotary, flapping, and even lighter than air (LTA) however, for the same reasons that birds and insects use flapping wings one might expect MAVs of this scale to also benefit from flapping wing performance and control.

Although the majority of MAVs flying today are fixed wing vehicles with propellers, the truly innovative designs that will meet mission needs for slow-flight indoor operations where size really matters, will be configured differently. Those designers who have stepped "outside of the box" have typically been drawn to biology as a source of inspiration. Making fixed wing propeller-driven aircraft very small results in evolutionary innovation (improved wings, improved materials, optimized propellers, etc.) whereas moving into the realm of biological designs requires many revolutionary innovations that are system-wide and much more than incremental improvements. They are in some cases, entirely new ways to approach the problem.

BIOLOGICAL INSPIRATION

In an attempt to leverage what already works at small flight scales, many researchers have turned to birds and insects as models, with the humming bird and the hawk moth being favorite analogs. In most cases however, a biomimetic approach has been taken wherein the avian or insect analog is copied. Since everything in creation that flies under power uses flapping wings, this has resulted in the construction of many flapping wing machines.

Almost universally, these flapping machines produce kinematically-correct, but symmetric, wing flapping. The mechanisms used to flap the wings are often mechanically coupled, allowing only hovering or steady forward flight [6]. The mechanisms used by the insects and birds to modulate the flight envelope in speed, direction, and orientation are not replicated in these designs. The researches' goal may only be to study the unsteady aerodynamics of the flapping wing at a design point, but often free flying systems are extrapolated from these experiments with little regard for the complexity of miniaturized, fully controlled and self-powered free flight machines that are manufacturable.

It is important to make a distinction between *biological mimicry* (biomimetics) and *biological inspiration*. A completely biomimetic solution is difficult to design with current technology and may be even more difficult to implement. Biological inspiration on the other hand, may lead to a better solution for a given design space than that afforded by the biological entity itself. That is, one might do well to use biological models as a starting point, but not allow the design to be constrained by the limitations of the model— in fact, going beyond the biological model could provide an even better solution than the original source of inspiration.

Consider the following ground-based example: given the task of getting from point A to point B along a prepared road surface in the minimum amount of time while expending minimum energy, is it better to hop like a frog, “slide” like a snail, slither like a snake, or crawl like a lizard? In each case, a biological analog can be copied, but the optimal solution lies outside the biomimetic box altogether. As a means of regular locomotion, the wheel does not occur in nature, but for the posed example, wheels provide a better solution than any of the biomimetic approaches.

The author suggests ten principals that should always be considered when embarking upon the design of a robotic flight vehicle that intends to leverage some aspects of a biological system:

Figure 3.

- | Michelson's Aphoristic Decalogue of Flight Biomimetics | |
|---|---|
| 1. | Biomimetics is a good starting point. |
| 2. | Strict adherence to biomimetic “guidance” can result in non-optimal performance solutions or unmanufacturable systems. |
| 3. | Thinking outside the box is always desirable, but sometimes optimal solutions fall within “the box”. |
| 4. | Biomimetic point solutions may not be practical apart from the “system”. |
| 5. | Simply being able to beat wings isn't enough— one must be able to develop the power necessary to fly. |
| 6. | Biomimetic flapping is structurally complex, leading to difficulties in flight control, manufacturing, and weight. |
| 7. | Means to control stability and to navigate are non trivial. |
| 8. | Poor integration of all flight systems leads to unmanageable weight. |
| 9. | Designs which do not capitalize on resonance waste energy. |
| 10. | The average power density for present battery technology is marginal for small scale flapping wing flight. |

1. *Biomimetics is a good starting point.* There is a wealth of untapped knowledge contained in the realm of nature. In most cases biological systems outperform anything devised by mankind when considering applications that are not on the fringe of performance (extreme temperatures, speeds, etc.). It is therefore reasonable to gain an understanding of how biological systems cope with situations that are also of interest to design of aerial robots.
2. *Strict adherence to biomimetic “guidance” can result in non-optimal performance solutions or unmanufacturable systems.* Merely copying biological morphology, kinematics, or behavior may not lead to an optimal robotic solution simply because it is derived from a biological entity, but should such a solution be achieved, it may be unimplementable due to external constraints. These constraints could include the inability to reproduce analogs for biological structures due to lack of suitable materials or nonexistent manufacturing processes.

3. *Thinking outside the box is always desirable, but sometimes optimal solutions fall within “the box”.* The obvious is not always apparent to those who are seeking innovative solutions. The allure of biological inspiration may tempt the designer to first consider how natural systems implement certain behaviors without considering well established techniques. Everything in creation that flies, does so with flapping wings; but there is little warrant to begin a new passenger aircraft design by considering hummingbird wing mechanics.
4. *Biomimetic point solutions may not be practical apart from the “system”.* Components of biological systems typically work in concert with one another synergistically to achieve extraordinary behaviors. Copying a single facet of a biological system may not achieve the desired result in the absence of its supporting elements. The flight control and sensory systems of a bird allow it to transition from forward flight to a precision perch on small surfaces (e.g., the top of a flag pole). To merely implement a flapping wing does not impart the ability required by an aerial robot to perch like a bird.
5. *Simply being able to beat wings isn’t enough— one must be able to develop the power necessary to fly.* Many flapping wing machines have been devised which aptly demonstrate the correct kinematics for flight, but few can support their own weight in flight, much less that of their power source. Apart from the fabled flights of Icarus, attempts such as DaVinci’s human-powered flapping wing machine have been tried with no success over the ages. Synthetic muscle technologies such as piezoelectric elements, shape-memory alloys, rheological fluids, and electro-polymers offer an array of electrically-controlled actuators which have been touted as a potential source of power for biologically-inspired robots, but all have yet to demonstrate sufficient efficiency to lift even the best high energy density battery. Piezoelectrically-actuated flapping wings have been demonstrated to flap for hours from a single watch battery, but at no time was the battery in danger of being lofted into flight [7].
6. *Biomimetic flapping is structurally complex, leading to difficulties in flight control, manufacturing, and weight.* The muscle structure of an insect wing is very complicated with opposing muscles at divergent angles. In addition, the wing is intimate to the exoskeleton such that deformation of these structures results in wing motion and energy recovery in a resilient material called resilin. Bird wings have muscles at not only the base, but out the wing itself in order to control airfoil shape by deflecting feathers for nuances of control during maneuvers. Replication of these actuator systems in an aerial robot is not trivial. As the size of the aerial robot decreases, the difficulty in building and attaching actuators is compounded.
7. *Means to control stability and to navigate are non trivial.* Most demonstrations of wing flapping are typically less than truly biomimetic because although they may create lift, drag, and thrust, rarely has the ability to do this in a controlled asymmetric manner been incorporated in the design. The main reason is complexity and added weight. Control moments can be created in a flapping wing system by various means including changes in flap angle, span, rate, or wing angle of attack. Birds tend to use all of these flight modulation techniques whereas insects tend to rely mainly on asymmetric changes in angle of attack from one side to the other. Mechanical implementations of these independently-controllable degrees of freedom are problematic at small scales, and heavy at larger ones. Is it any wonder that most free-flying flapping wing machines (e.g., ornithopters after DeLaurier; see Figure 4) end up being a synthesis of birds and airplanes? The flapping bird wings provide lift and thrust while an airplane tail (rudder/elevator) provides the moments necessary for controlled flight.
8. *Poor integration of all flight systems leads to unmanageable weight.* “Micro” air vehicles, the smallest aerial robots to have received serious attention, differ from larger aerial robots in not only their low Reynolds number surfaces, but also in design philosophy. Unlike larger UAVs which can be multipurpose “trucks” containing black-box subsystems, MAVs must have tightly integrated multipurpose systems in order to manage weight. Structures such as wings need to double as antennas, batteries can become aerodynamically conformal— even becoming part of the air vehicle structure itself. Just as a mammal’s bones provide structure, hinge points, attachments for musculature, and serve as red blood cell factories, so the components of a tiny air vehicle must exhibit multiple functions for the sake of efficiency. Aerovironment has demonstrated a battery that serves as part of the wing structure



Figure 4. A DeLaurier 2002 flapping wing machine: a synthesis of birds and airplanes. [29]

in order to reduce weight and increase endurance in their WASP MAV (see Figure 5) [8]. The biologically-inspired Entomopter is one of the most integrated MAV designs with a chemical propulsion system that not only creates thrust and lift, but also enables flight control, joint lubrication, obstacle avoidance, altimetry, and electrical power generation [9].



Figure 5. AeroVironment “Wasp” MAV. [28]

9. *Designs which do not capitalize on resonance waste energy.* All creatures capable of sustained powered flight do so with resonant systems. Flight is expensive from an energy standpoint. Brute force biological wing flapping can result in flight, but at a great cost in fuel. Fuel is heavy, so a practical limit on the fuel that can be carried also places a limit on endurance. The act of flapping a wing involves accelerating a mass in one direction and then decelerating the same mass in preparation for a reversal in direction. Brute force flapping burns energy to achieve this reversal. Biological systems store kinetic wing energy within their structures as potential energy to be released upon wing reversal. This is the basis for a resonant system that requires only periodic (at the fundamental resonant flapping frequency) energy input rather than a continuous brute force energy expenditure to accelerate wing mass only to fight its inertia moments later.
10. *The average power density for present battery technology is marginal for small scale flapping wing flight.* Small birds and insects are consumed with the task of energy harvesting: the search for food. Hummingbirds, the smallest of all avians, feeding on dilute nectar can ingest nearly three times their body mass in nectar per day to sustain life and mobility [10, 11]. Their small bodies can not carry large amounts of food, so to improve efficiency they choose high energy foods that provide immediate energy access (sugars) as do many insects. Tiny aerial robots suffer from the same need for readily available energy. The energy density of the best battery technologies currently available still cannot match that which is locked chemically in various compounds such as sugars. For example, more energy can currently be extracted from a drop of gasoline than a battery the size of a drop of gasoline. Some have advocated energy harvesting through the use of solar panels on MAVs. Unfortunately the efficiency of current solar cells (roughly 5% for common cells, ranging up to 28% for some of the best triple-junction gallium arsenide space-qualified cells) in sizes that could be carried by a MAV is insufficient for sustained flight [12]. The extra weight of such cells negates their use as an endurance extender and their low voltage output is incompatible with many of the electronic actuators proposed (e.g., piezoelectric, electro polymers, etc.). Finally, night operation or flight through shadows is precluded.

DESIGN EXAMPLE

An example of a MAV that demonstrates high degrees of innovation, extreme integration, and biological inspiration is the Entomopter. It embodies the ten principals outlined above and is described here as one example of how these principals can, and have been, applied to a MAV system.

Once it was realized that indoor operation was desirable, and that highly maneuverable slow flight and obstacle avoidance were necessary to the prosecution of indoor missions, the design process began by asking “what configuration could best meet these requirements?” Fixed wing approaches were eliminated due to their speed, which made obstacle avoidance, landing, and taking off again problematic. Lighter-than-air approaches could not carry adequate payload for vehicles in the 15 cm size range. Rotary wing approaches although feasible, were determined to be inferior to flapping wing designs because of acoustic signature, lack of robustness (rotors striking objects do not survive and lose weight efficiency if shrouded), and the inability to conserve energy through the application of resonance. On the other hand, flapping wings have been observed in indoor environments on many occasions where birds and insects have invaded living spaces. These biological entities fly almost silently, can sustain a wing strike with objects (walls, ceilings, etc.) and survive unscathed, while being agile enough to avoid obstacles and even perch when necessary. Flight reinitiation from a stationary posture is also observed.

The ‘Entomopter’ (*entomo* as in entomology + *pteron* meaning wing, or a “winged insect machine”) began not as an air vehicle, but as a propulsion concept once a flapping wing solution had been adopted as a general system architecture. The Entomopter is a multimode autonomous robot capable of flight, ambulatory locomotion, and swimming behaviors in a single vehicle (see Figure 6). Autonomous navigation is based on a combination of attraction and avoidance behaviors deriving input from both an integrated optic olfactory sensor for detection and

tracking of chemical species (or, alternatively, a sensor for a specific type of radiation), and an ultrasonic swept beam ranging device. Since the flapping wing was chosen as the best approach for flight, the other modes of locomotion (crawling or swimming) were based on the same actuation system as that used for flapping wing flight, but do not involve the complexity, precision, or energy expenditure associated with flight.

Terrestrial Entomopter feasibility was established under contract to the DARPA Defense Sciences Office Mesomachines Program, where it is referred to as a Mesoscaled Aerial Robot (MAR). The Air Force (AFRL) then issued a contract under its Revolutionary Technology Program to extend the flight muscle into the fourth generation of size reduction and performance enhancement (see Figure 7). Of particular interest to the Air Force and others is the potential for swarms of Entomopter vehicles to rapidly penetrate denied areas, such as deeply buried underground facilities. This is possible because of the Entomopter's size, multimode locomotion, and anaerobic propulsion system, which allows covert ingress through sewer pipes, ducts, or electrical conduits.

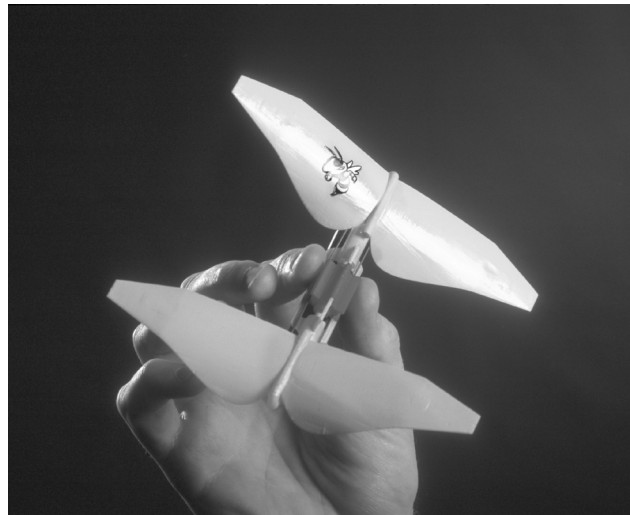

Figure 6. Terrestrial Entomopter 15cm wing span kinematically-correct stereolithographic model.

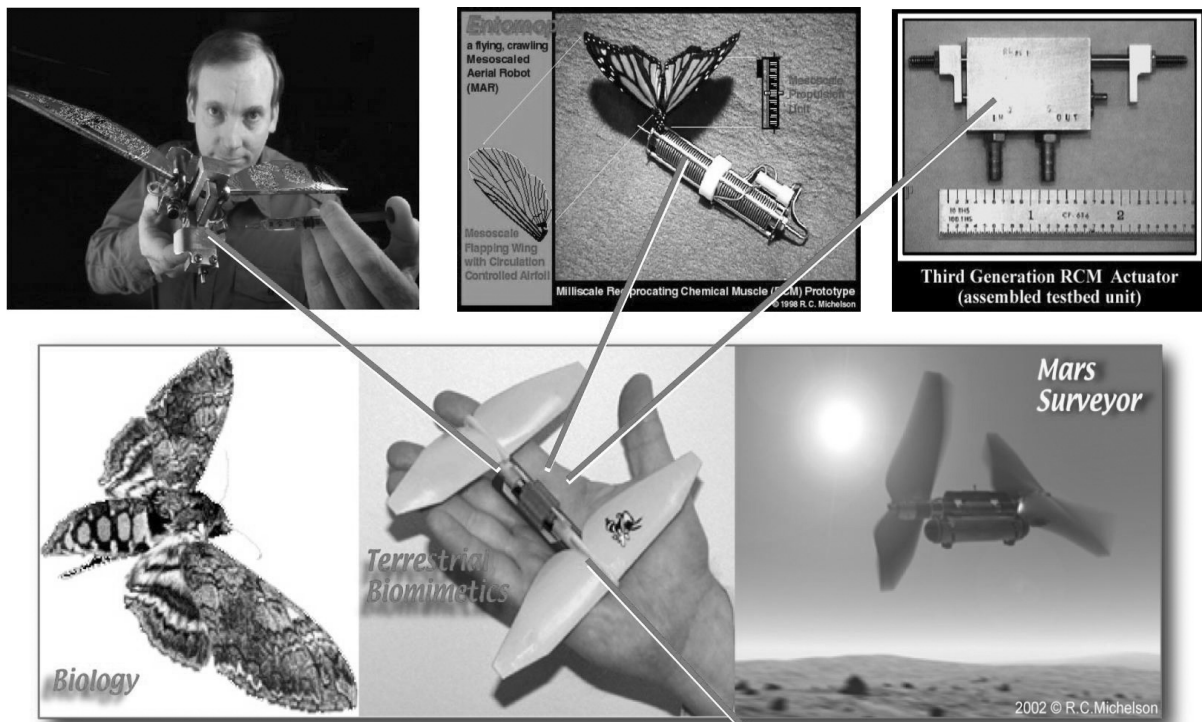
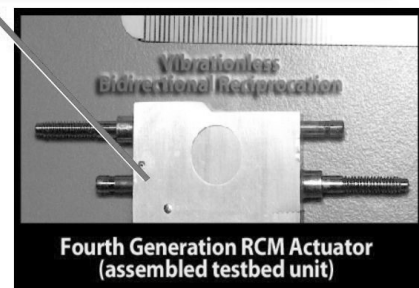

Figure 7. Generations of the Reciprocating Chemical Muscle Actuator.

NASA personnel recognized the Entomopter's ability to fly in low Reynolds number conditions without the need for air-breathing propulsion made it a natural candidate for flight in Mars' rarefied atmosphere, albeit in a larger incarnation. Unlike fixed wing flyers, an Entomopter-based Mars surveyor would be able to cover a wide area while still being able to fly slowly, land, crawl, obtain surface samples for analysis, and return to a refueling rover. As of this writing, two patents have been issued for the Entomopter concept, and the reciprocating chemical muscle that is integral to the Entomopter's operation.



The Entomopter began as a biologically inspired design, but rather than attempting to replicate biological kinematics and aerodynamics, improved systems have been devised to leverage what is observed in biological systems to produce a machine that is manufacturable, controllable, and able to generate the power necessary to fly from onboard energy sources. Just as wheels are superior locomotors under certain circumstances but are not a common form of locomotion for biological systems, so the Entomopter has extended its design beyond the biological baseline in some areas.

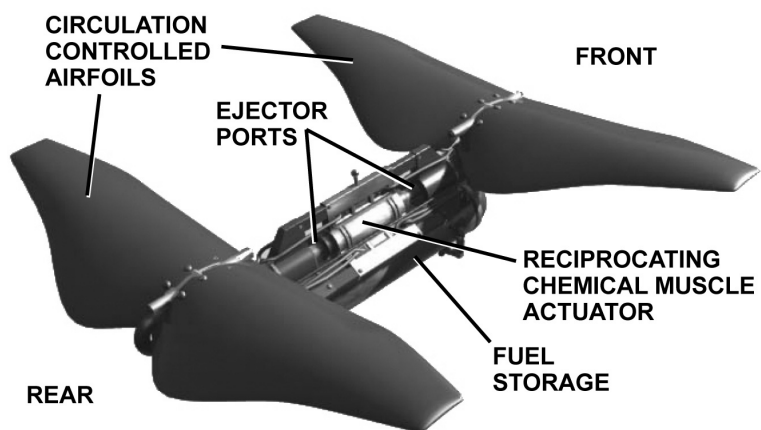

Figure 8. Entomopter morphology.

The morphology of the Entomopter is shown in Figure 8. The fixed frame-of-reference fuselage contains the propulsion actuator, fuel supply, sensors, and flight computer. Twin wings are used, one at each end of the fuselage to enhance pitch stability. Maximum separation of the wings also mitigates the effects of front wing shed vortices on the rear wing. Unlike a dragon fly, the Entomopter’s rear wing is not intended to manipulate the vorticity created by the front wing.

The Hawk Moth (*Manduca sexta*) was chosen as a baseline model for the wing aerodynamics. The University of Cambridge in England was part of the initial Entomopter design team because it had studied Hawk Moth wing aerodynamics for more than a quarter of a century and had produced seminal works describing the Leading Edge Vortex (LEV) and its effects on the flapping wing [13, 14, 15, 16, 17].

The flapping mechanism for the Entomopter has been extended beyond that of the Hawk Moth to provide a resonant single-piece “X-wing” construction that takes advantage of torsional resonance in the Entomopter fuselage to recover flapping energy as is common to flying insects which temporarily store potential energy in either muscles or exoskeletal parts (resilin). Although there are a number of resonant modes within the Entomopter, the main resonance of interest here is that associated with the wing flapping frequency and results from the fore and aft wing twisting a torsion spring that separates the wings and is parallel to the fuselage. It is this opposite (180 degree out of phase) flapping of the fore and aft wings that interact across the fuselage torsion spring to create a resonant circuit (see Figure 9).

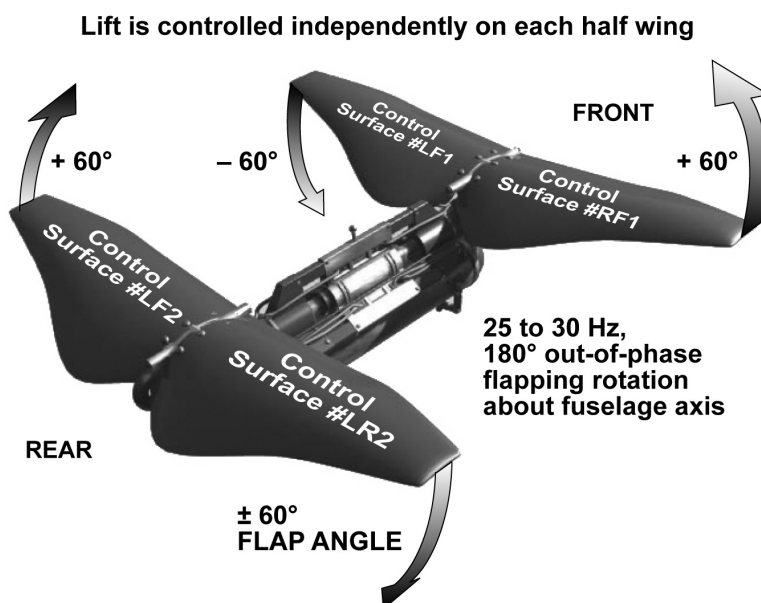

Figure 9. X-Wing flapping kinematics

This particular resonance contributes the most to energy recapture during the flapping process and is beneficial since the flapping mechanism is designed to be autonomic and of a single resonant frequency (between 25 - 30 Hz for the terrestrial Entomopter– see Figure 10). Other resonances such as the axial and chord-wise flexure of the wings do not contribute significantly to energy recapture during flapping and in some cases would be counterproductive were it not for the fact that they occur at frequencies that are mismatched to the fundamental flapping frequency.

A chemically fueled reciprocating chemical muscle has been designed and is in its fourth generation of development at the time of this writing. This actuator system has demonstrated 70 Hz reciprocation rates with throws and evolved power levels necessary to support flight, crawling, or swimming of a self-contained fully autonomous Entomopter system [18]. The reciprocating chemical muscle uses the energy locked in various chemical fuels to

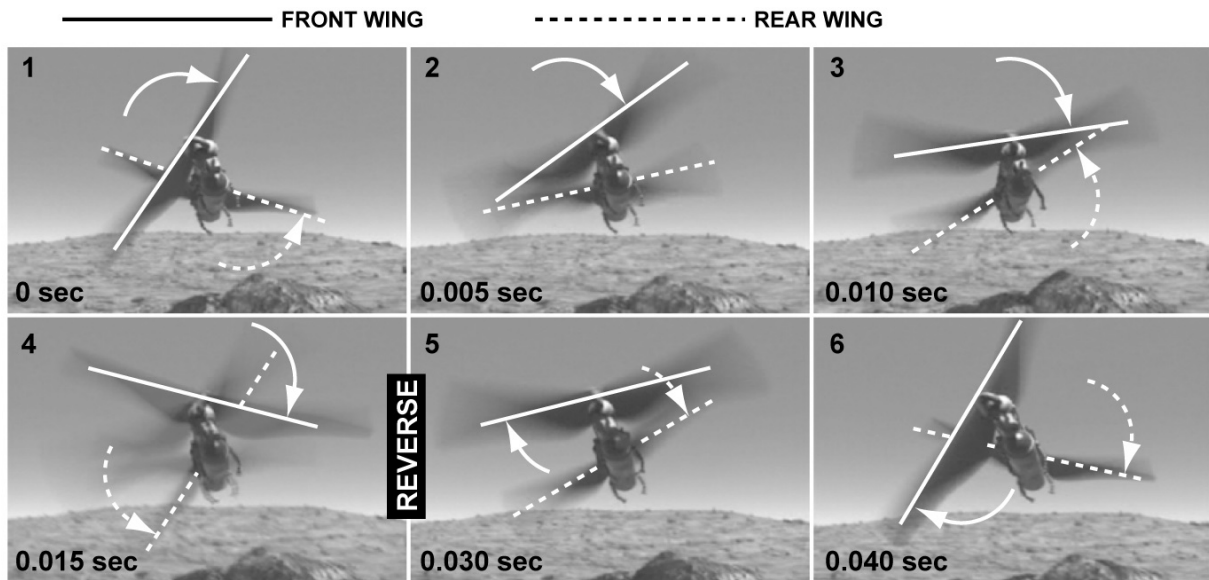

Figure 10. X-Wing flapping sequence.

produce reciprocating motion for propulsion as well as waste gas products for the operation of gas bearings, an ultrasonic obstacle avoidance ranging system, and full flight control of the vehicle. In all, precious and limited energy stored onboard this 50 gram MAV is used up to seven times before it is released. These uses are:

Energy Use 1. A regenerative muscle that consumes various fuel types in a noncombustive process that yields forces and frequencies consistent with flapping wing flight at the scale of a 15 cm MAV. The muscle works in explosive atmospheres, requires no atmospheric oxygen, and can even work underwater. By extracting mainly heat energy from the exothermic decomposition of the chemical fuel, the wings are driven to flap autonomically at a resonant frequency. Other modes of locomotion such as crawling, jumping, and even swimming use this same mechanism.

Energy Use 2. Reuse of muscle waste gas for independent circulation-controlled lift modification of the right and left sides of each wing allows stable flight as well as the ability to change heading for navigation. Stability and control in flight as well as navigation are achieved by actively modifying the lift of each wing on a beat-to-beat basis using pneumatic control of both the laminar flow and the leading edge vortex circulating over the beating wing. Also, as demonstrated in GTRI's wind tunnels, where pneumatically controlled wings have been shown to develop positive lift at negative angles of attack (α) as great as -70° [19, 20], Entomopter wings (unlike those of the Hawk Moth) should be able to generate positive lift not only the downbeat but the upbeat as well. These wind tunnel tests have shown that coefficients of lift exceeding the theoretical maximum by 500% for the given wing shape can be achieved without the complexity of active angle-of-attack modulating mechanisms. The Entomopter control scheme involves only a pair of duty-cycle modulated flapper valves rather than a myriad of individual actuators to control wing angle of attack, flap angle, and beat frequency. As such, the Entomopter is *not* a synthesis of a flapping wing and an airplane tail. It derives all of its lift, thrust, AND control from its wings alone, and it is simple enough to be manufactured affordably.

Energy Use 3. A steerable beam frequency modulated continuous wave (FMCW) acoustic obstacle avoidance system that uses waste gas from the Reciprocating Chemical Muscle and wing motion to sense both altitude above the ground and obstacles such as walls. The FMCW transmission capability is inherent in the Reciprocating Chemical Muscle at no energy cost. Specifically, waste gas from the Reciprocating Chemical Muscle is used to produce ultrasonic energy which is modulated by the wing beat angle to create the requisite waveform necessary for Doppler-insensitive range determination. This has been demonstrated during GTRI's DARPA-funded MAR program to allow ranging out to a distance of approximately 4 meters from a system scaled to fit on the 15 cm Entomopter [21]. In the terrestrial version, the same structure that provides wing flapping also scans the FMCW ultrasonic beam to provide front, side, and down-looking range measurements for obstacle avoidance and altimetry. Further, this ranging design has the potential to track and follow free-moving agents in a fashion similar to that employed by bats.

Energy Use 4. A limited amount of onboard thermoelectrically-generated electric power derived from Reciprocating Chemical Muscle waste heat resulting from the controlled exothermic decomposition of the fuel that can be used for the obstacle avoidance receiver electronics and onboard intelligence. This can be augmented by other energy harvesting techniques (e.g., solar) as well.

Energy Use 5. A mass flow amplifier based on an ejector to supply higher volumes of lower pressure, cooled gas for use in circulation control of the wings. The ejector entrains external atmospheric gases into the waste gas flow which not only enhances circulation control performance, but allows lower temperature components to be used down stream from the ejector.

Energy Use 6. Gas bearings for all moving mechanical interfaces. No wetted surfaces or lubricants are required because waste gas is used as a bearing surface. This also increases reliability by continuously repelling contaminants that could foul joints and cause wear or excessive friction.

Energy Use 7. Directional thrust. If sufficient energy remains in the waste gas, it can be expelled intelligently to provided a degree of directional thrust for launch assist, breaking, or maneuvering in flight.

SUMMARY

Additional details of Entomopter morphology can be found in various references [22, 23, 24, 25, 26, 27]. The foregoing high level description of the Entomopter system is illustrative of the challenges encountered during the design of miniature flight platforms, and especially addresses the most interesting and potentially useful class of MAVs, those that are biologically-inspired. Beyond low Reynolds number aerodynamics and extreme miniaturization, the MAV designer must address high levels of system integration, efficient use and reuse of energy, and systems that can be physically and affordably manufactured once designed. The Entomopter is an example of the high degree of innovation required to make practical miniaturized flying machines on the scale of small birds and insects. It is also very much an example of how to think “outside the box” to capitalize on biological systems (flapping wings, crawling, echolocation), while not to stopping with mere biomimicry, but going beyond to improve upon these natural systems (torsional X-wing flapping, circulation control of wing aerodynamics to achieve additional lift, thrust, and control through a single mechanism). Certainly the application to which a biologically-inspired MAV will be placed is one of the most significant design drivers, and the features to be incorporated into the biologically-inspired MAV will vary accordingly. But the ten principals outlined herein will be universally fundamental to the design of an efficient and affordable biologically-inspired MAV regardless of the application.

REFERENCES

1. **Hundley, Richard O., and Gritton, Eugene C.**, “Future Technology-Driven Revolutions in Military Operations,” RAND Corporation, Document No. DB-110-ARPA, 1994.
2. **BBCi Sci/Tech**, “Cyberbugs are go”, Wednesday, March 4, 1998, at <http://news.bbc.co.uk/1/hi/sci/tech/61822.stm>
3. **Cheney, Margaret**, “Tesla: Man out of time”, ISBN 0-88029-419-1 Dorset Press, NY, 1981, pg. 7
4. **2002 personal communication** between Sam Wilson (DARPA) and Robert Michelson (GTRI)
5. **United States Department of Defense News Release** (on the web: http://www.defenselink.mil/news/Dec1997/b12121997_bt676-97.html), Media contact: media@defenselink.mil or +1 (703) 697-5131
6. **Sumitra Rajagopalan**, “Researchers Ape Nature With Flapping-Wing Aircraft -Versatile Ornithopters Hold Promise for Space or Military Missions” Special to The Washington Post, Monday, September 1, 2003; Page A09
7. **Salisbury, David F.**, “Vanderbilt engineers build robotic bugs that can go the distance”, Exploration: the online research journal of Vanderbilt University, http://exploration.vanderbilt.edu/news/news_roboticbugs_nsv.htm, December 1, 2000
8. **AeroVironment Online Press Release:** <http://www.aerovironment.com/news/news-archive/wasp62.html>
9. **Michelson, R.C.**, “The Entomopter,” Neurotechnology for Biomimetic Robots, ISBN 0-262-01193-X, The MIT Press, September 2002, pp. 481-509
10. **Powers, D. R. & Nagy, K. A.** “Field metabolic rate and food consumption by free-living Anna’s hummingbirds (*Calypte anna*)”. *Physiol. Zool.* 61, 1988, 500-506
11. **McWhorther, T. J. & Martinez del Rio, C.** “Food ingestion and water turnover in hummingbirds: how much dietary water is absorbed?”, *J. exp. Biol.* 202, 1999, 2851-2858
12. **Dornheim, M.Z.**, “Get Me Through the Night”, *Aviation Week & Space Technology*, September 15, 2003, McGraw-Hill, pg. 66-68

13. **Ellington, C.P., van den Berg, C., Willmott, A.P. and Thomas, A.L.R.**, “Leading-edge vortices in insect flight,” *Nature* 38:D 1996, pp. 626-630
14. **van den Berg, C. and Ellington, C.P.**, “The Vortex Wake of a ‘Hovering’ Model Hawk Moth,” *Phil. Trans. R. Soc. Lond. B*, 352, 1997, pp. 317-328
15. **Willmott, A.P., Ellington, C.P., and Thomas, A.L.R.**, “Flow Visualization and Unsteady Aerodynamics in the Flight of the Hawk Moth *Manduca Sexta*,” *Philosophical Transactions of the Royal Society B*, Vol 352, 1997, pp. 303-316
16. **Willmott, A.P. and Ellington, C.P.**, “The Mechanics of Flight in the Hawk Moth *Manduca Sexta*. I. Kinematics of Hovering and Forward Flight,” *J. exp. Biol.* 200, 1997, pp. 2705-2722
17. **Liu, H., Ellington, C.P., Kawachi, K., van den Berg, C. and Willmott, A.P.**, “A Computational Fluid Dynamic Study of Hawk Moth Hovering,” *J. exp. Biol.* 201, 1998, pp. 461-477
18. **Michelson, R.C., Amarena, C.S.**, “4th Generation Reciprocating Chemical Muscle: Reciprocating Chemical Muscle (RCM) for Specialized Micro UAVs and Other Nonelectric Anaerobic Aerospace Actuation Applications”, Prepared under Grant No. F086300010007 to the U.S. Air Force Research Laboratories (AFRL/MNGN), October 15, 2001
19. **Englar, Robert J., Smith, Marilyn J., Kelley, Sean M., and Rover III, Richard C.**, “Development of Circulation Control Technology for Application to Advanced Subsonic Transport Aircraft, Part I: Airfoil Development” AIAA Paper No. 93-0644, Log No. C-8057, published in *AIAA Journal of Aircraft*, Vol. 31, No. 5, pp. 1160-1168, Sept-Oct 1994
20. **Englar, Robert J., Smith, Marilyn J., Kelley, Sean M., and Rover III, Richard C.**, “Development of Circulation Control Technology for Application to Advanced Subsonic Transport Aircraft, Part II: Transport Application” AIAA Paper No. 93-0644, Log No. C-8058, published in *AIAA Journal of Aircraft*, Vol. 31, No. 5, pp. 1169-1177, Sept-Oct 1994
21. **Michelson, R.C.**, “Mesoscaled Aerial Robot,” Final Report under DARPA/DSO Contract Number: DABT63-98-C-0057, February 2000, pp. 14-16
22. **Michelson, R.C.**, “Scaling of Biologically Inspired Aerial Robots,” 5th International Workshop on Similarity Methods, Institut für Statik und Dynamik der Luft- und Raumfahrtkonstruktionen, Universität Stuttgart, 4 - 5 November 2002, pp. 71-78
23. **Colozza, A., Michelson, R.C., et al**, “Planetary Exploration Using Biomimetics – *An Entomopter for Flight on Mars*,” Phase II Final Report, NASA Institute for Advanced Concepts Project NAS5-98051, October 2002
24. **Michelson, R.C.**, “The Entomopter,” *Neurotechnology for Biomimetic Robots*, ISBN 0-262-01193-X, The MIT Press, September 2002, pp. 481-509
25. **Michelson, R.C., Ahuja, K.K., et al**, “Mesoscaled Aerial Robot,” Final Report under DARPA/DSO Contract Number: DABT63-98-C-0057, February 2000
26. **Michelson, R.C.**, “Update on Flapping Wing Micro Air Vehicle Research– *Ongoing work to develop a flapping wing, crawling Entomopter*,” 13th Bristol International RPV/UAV Systems Conference Proceedings, Bristol England, 30 March 1998 - 1 April 1998, pp. 30.1 - 30.12
27. **Michelson, R.C.**, “A Reciprocating Chemical Muscle (RCM) for Micro Air Vehicle “Entomopter” Flight,” 1997 Proceedings of the Association for Unmanned Vehicle Systems, International, June 1997
28. **AeroVironment Press Release** dated 8-19-2002, “AeroVironment’s “WASP” Micro Air Vehicle Sets World Record”, available at: <http://www.aerovironment.com/news/news-archive/wasp62.html>
29. **Project Ornithopter website** available at: http://www.ornithopter.net/images/2002/medium/Flapper7_2002.jpg
30. **God’s World Today, September 27, 1966** available at: http://www.ornithopter.net/images/2002/medium/Flapper7_2002.jpg

- Figure 1. Copyright 2003, R.C. Michelson
 Figure 2. Copyright 1966, God’s World Today
 Figure 3. Copyright 2002, R.C. Michelson
 Figure 4. Copyright 2003, Project Ornithopter
 Figure 5. Copyright 2002, AeroVironment, Inc.
 Figure 6. Copyright 2002, Georgia Institute of Technology/Meeks
 Figure 7. Copyright 2002, R.C. Michelson/Leary/Georgia Institute of Technology
 Figure 8. Copyright 2002, R.C. Michelson/Leary/Georgia Institute of Technology
 Figure 9. Copyright 2002, R.C. Michelson/Leary/Georgia Institute of Technology
 Figure 10. Copyright 2002, R.C. Michelson/Leary/Georgia Institute of Technology

NOTE: This paper is the basis for a chapter in the text, “*21st Century Aerial Robotics*” by Michelson and Newcome.